

## GROM Interface Installation into FORD / Lincoln / Mercury cars

### ***Tools needed***

Wire crimp tool (optional), screwdriver, phillips driver

### ***Preparation***

1. Turn off car's engine and remove key from ignition
2. Take the screwdriver; carefully insert the slothead between the car stereo trim and dashboard. Gently remove the car stereo trim.



3. Now you see the stereo and 4 screws at the stereo corners.



1. Take the Phillips driver and unscrew 4 screws at the stereo corners.



5. Gently pull the stereo out, be careful not to disconnect any wires.



6. Open the glovebox. Take the FORD OEM harness (FRD07 in your GROM package) and guide it through the hole in your glovebox to the dashboard. The

end of FRD07 that connects to the stereo should go inside the dash, and the other end that connects to the GROM box should be left in the glovebox.



7. Locate the power lid (yellow wire with the pink colored quick disconnect terminal on the end).



8. Locate the main harness at the back of the Ford stereo, find the red colored power wire on it.

9. Snap the T-Tap clip (provided with your GROM package) over the red wire on the main harness so it is fastened

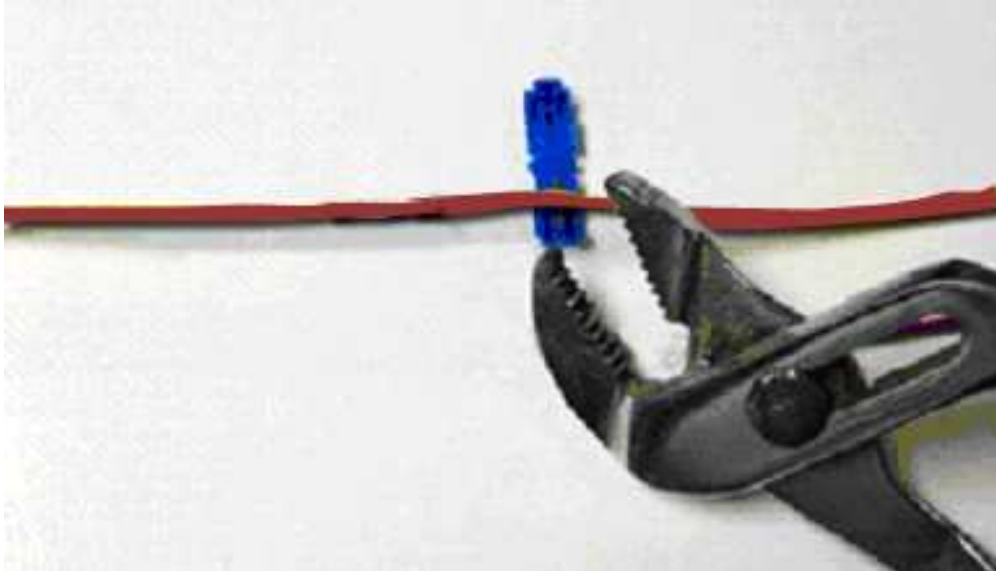

10. Connect the power lid to the red power wire on the main harness as shown below. You can simply snap the pink disconnect with the closed T-Tap clip on the red harness.

### Location of the red power wire

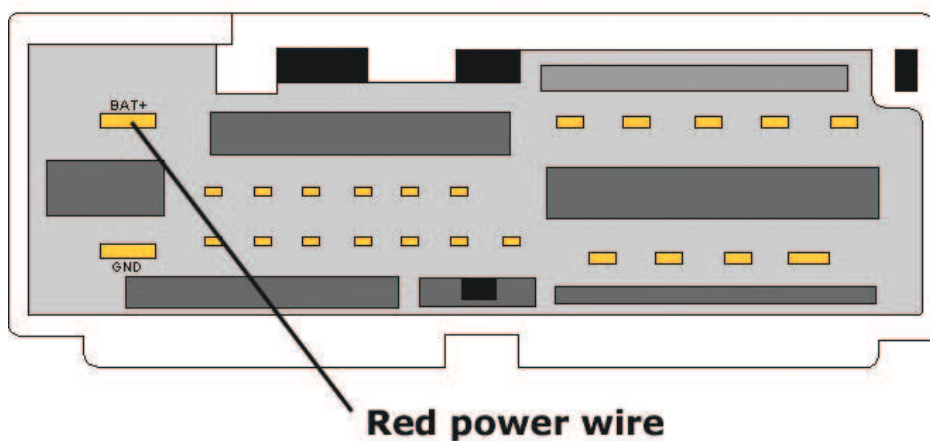

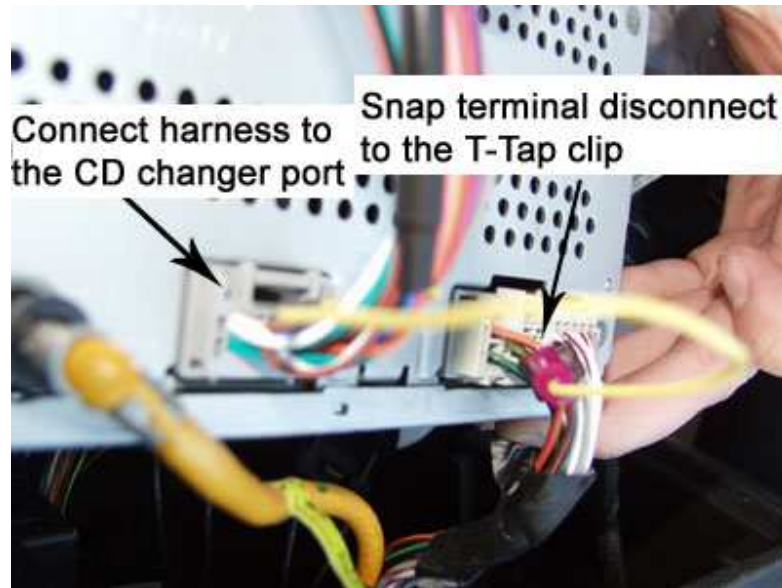

11. Locate the empty CD changer port and connect the FRD07 harness to it. Make sure that the connection is firm and the harness is securely attached to the port.\*
12. Connect your GROM-USB MP3 car kit to the other end of FRD07 harness. You can now start using your GROM-USB!
13. Test your GROM USB adapter before you put the stereo back! You can try it with USB stick provided in your package. Please don't forget to place your favorite tunes on the USB stick.
14. If everything is working as it should - carefully place the stereo back until it snaps to its place. If not - see troubleshooting section in your User Manual.

\* **Note:** If the port is occupied with the other cable (for example XM), please follow to the steps below:

1. Disconnect this cable
2. Connect male end of FRD07 OEM harness
3. Insert the unplugged cable back to the car stereo using the female port on the FRD07 harness
4. Please make sure that everything that you unplug from the car stereo is connected back!

### **3. Disclaimer**

- This product is not affiliated with any of the OEM manufacturers
- Modifying the radio may void any existing warranty
- The purchase of this product carries no warranties, either expressed or implied
- Although every care has been taken to provide a quality product, we cannot guarantee that the GROM USB adapter will function correctly if installation is not done according to the instructions included in this guide. Furthermore, we cannot guarantee the GROM USB adapter to function correctly with a USB device that is broken, damaged, or not supported
- Keep your eyes on the road while driving!
- We are not liable for the misuse of this product, including improper installation, damage to the board or radio during installation, and the illegal use of the radio